

## **Manzanillo Container Terminal Redevelopment: Maximizing Throughput in a Limited Space**

John Bardi, PE, MASCE<sup>1</sup> and Ing. Daniel Ingram<sup>2</sup>

<sup>1</sup>Senior Project Manager, BergerABAM, 33301 Ninth Avenue South, Suite 300, Federal Way, WA 98003-2600; PH (206) 431-2300; john.bardi@abam.com

<sup>2</sup>Construction and Facilities Manager, SSA Mexico SA de CV, Insurgentes Sur No. 1898, Col. La Florida, Mexico, DF 03010; PH +55/5482-8212; daniel.ingram@ssamexico.com

### **ABSTRACT**

Increased container volumes make Manzanillo one of the fastest-growing ports on the west coast of Mexico. In the 14 years since the concession for the dedicated container terminal was awarded as a single berth, annual traffic has grown from 50,000 to approximately 750,000 20-foot equivalent units (TEUs), the number of berths has grown to four, and the container yard has been expanded almost four-fold to its practical limit of 30 hectares (approximately 74 acres). Because the yard expansion followed a layout established when the original single-berth facility was constructed, it required reconfiguration to attain maximum efficiency in terms of TEU throughput per hectare of yard.

This paper describes the planning, design, and construction involved in retrofitting and redeveloping the terminal. The terminal was redeveloped with a revised yard layout and retrofitted with new lighting, utilities, and a heavy-duty paving system to maximize density and allow the effective use of electrified rubber-tired gantry cranes. The yard is located in an area of high seismic hazard and the paper also discusses the ground improvement program that was implemented to mitigate the risk of earthquake-induced liquefaction.

Finally, the paper discusses the retrofit of the existing container wharves to accommodate four post-Panamax container cranes. Two cranes were modified to match the existing rail gauge of 16.76 meters (55 feet), while two were left with the original 34.80-meter (115-foot) gauge and required construction of a third rail. The installation of the cranes required retrofitting the crane cable infrastructure and relocating cable slots from the backreach area to the opposite side of the waterside crane rail.

### **INTRODUCTION**

SSA Mexico (SSAM) was awarded a concession at the Port of Manzanillo's dedicated container terminal in mid-1995, or approximately four years after the completion of the Port's first dedicated container berth in 1991. Since that time, throughput has increased from approximately 50,000 to 750,000 20-foot equivalent units (TEUs) per year, and the terminal has grown from an initial size of 6 hectares

(15.8 acres) and one 250-meter (820-foot) berth to 30 hectares (74 acres) and 1,000 meters (3,280 feet) of berth. Currently, SSAM also makes occasional use of the adjacent 300-meter (984-foot) multipurpose berth built by the Autoridad Portuaria Integral de Manzanillo (API-MAN) in 2001, bringing the total length of available berth to approximately 1,300 meters (4,265 feet).

The terminal is located in an area of reclaimed swamp, on a strip of land sandwiched between the Bay of Manzanillo on Mexico's west coast and the Laguna de Tapeixtles, as shown in Figure 1. The existing geotechnical conditions consist of 18 to 20 meters (59 to 65 feet) of alluvial materials, composed of alternating layers of loose sand and silt interspersed with lenses of peat. Analysis has shown that these loose sand deposits are subject to liquefaction under moderate levels of shaking – a phenomenon that was observed in the field in earthquakes in both 1995 and 2003, first to disastrous effect, and later mitigated by ground improvement.

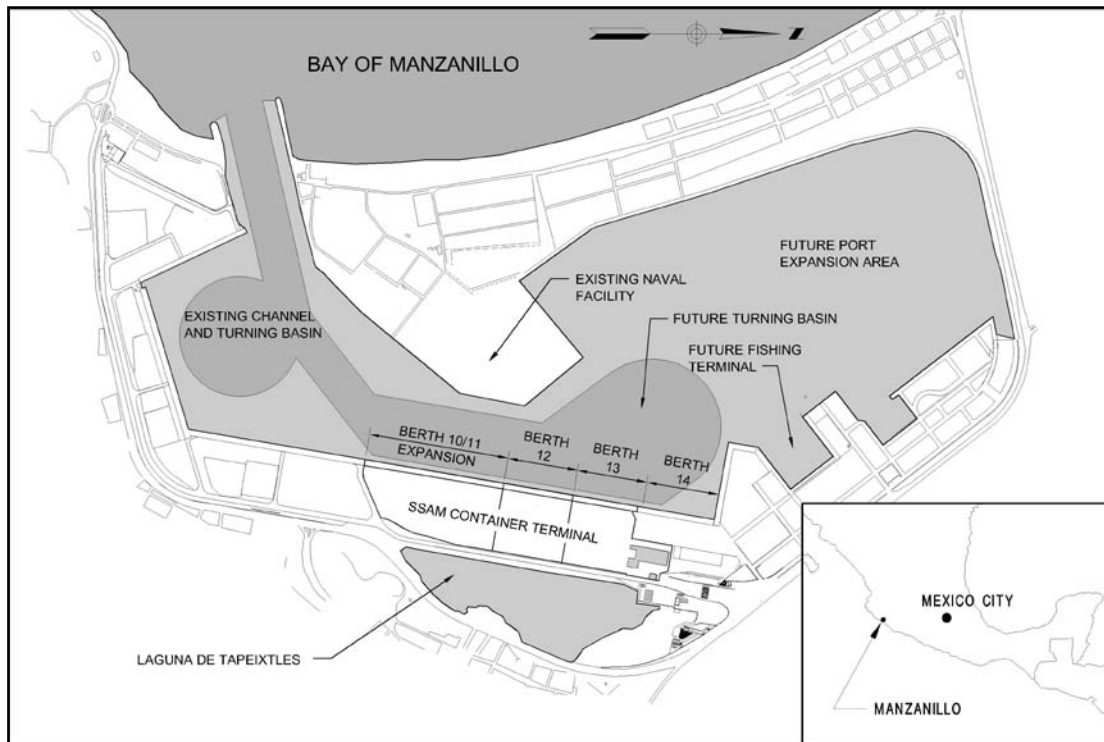

**Figure 1. Site plan.**

The western coast of Mexico is a region of very high seismic activity. The state of Colima, of which Manzanillo is the second-largest city and the largest on the coast, is considered to be an area of particularly high hazard because of the proximity of the Colima volcano, the most active in the region. The quantitative seismic hazard of the area around the Port of Manzanillo is very high, with a peak ground acceleration of the maximum considered earthquake (MCE) equal to 0.86g according to the seismic provisions in the most commonly used Mexican seismic design code (Comision Federal de Electricidad 2001).

## BERTHS 12 AND 13

Located at the north end of the concession, Berths 12 and 13 comprise the older part of the terminal and were planned and developed using the 1991 operating criteria. The Berth 13 container yard was damaged severely by an earthquake in 1995. Its subsequent reconstruction, and the construction of the Berth 12 container yard, incorporated a ground improvement program of stone columns and wick drains to mitigate the risk of earthquake-induced liquefaction.

This oldest portion of the terminal assumed a dedicated rubber-tired gantry (RTG) operation, originally using 4-wheel (and later 8-wheel) machines operating on dedicated concrete runways. Figure 2 shows the typical layout of the Berth 12 container yard at the time of its construction in 2000, when it was laid out to match that of Berth 13.

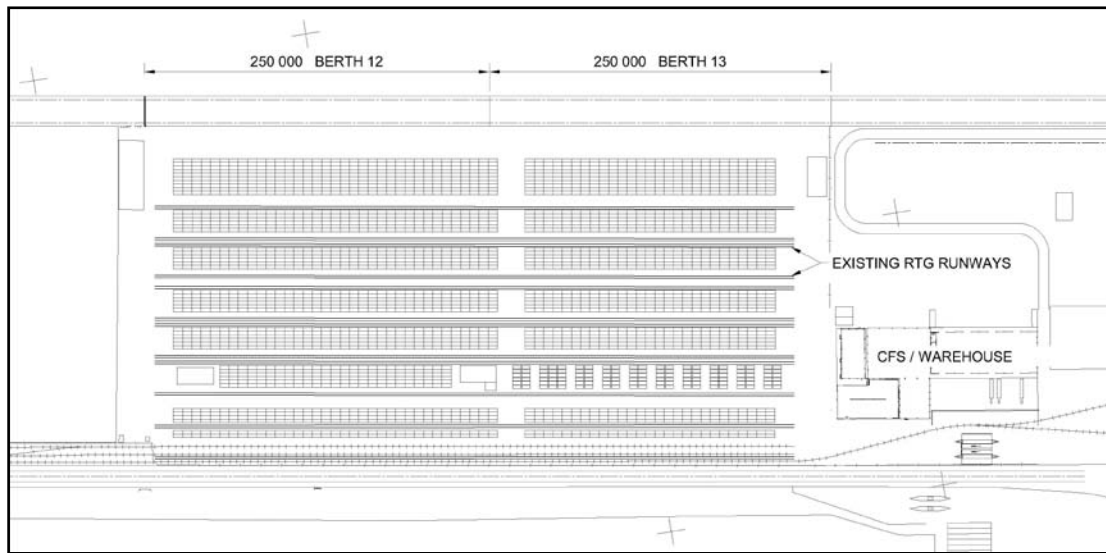

**Figure 2. Berths 12 and 13 container yard layout.**

The RTG runways and high mast light poles were laid out to allow traffic circulation on either side of each machine, with truck bypass areas provided by setbacks from the intermodal area and the wharf. In use, the waterside portion of the yard was devoted to top-pick operations, and wider bypass lanes were used for equipment parking.

The Berths 12 and 13 container yard exhibited good performance during the 2003 earthquake. The investment in stone columns proved to be the right choice; when neighboring terminals with similar block paving on unimproved soils were inspected, they had experienced heaving of pavement as high as 450 millimeters (nearly 18 inches). The only exception to this good result at the SSAM terminal came in isolated areas at the north and south boundaries of the improved ground and in the Berths 10/11 expansion area, which was unpaved at the time and developed extensive sand boils and lateral spreading.

While ground improvement had been shown to be successful, the selected block paving system did not perform as well. Through heavy use by top-picks and where

RTGs were operated off the runways, block deterioration, settlement, and rutting were ongoing maintenance issues. Inspection determined that the chief problem had been the composition of the block, although problems with the paving base were also noted, particularly in areas of top-pick operation.

### BERTHS 10 AND 11

Expansion of the container terminal concession southward into Berths 10 and 11 was approved in 2007. As planning of the yard expansion was begun, lessons learned from the performance of the Berths 12/13 yard were incorporated. As described above, these included a ground improvement program, an improved paving system, and an optimized yard layout designed to maximize the relatively small available yard area, as indicated on Figure 3.

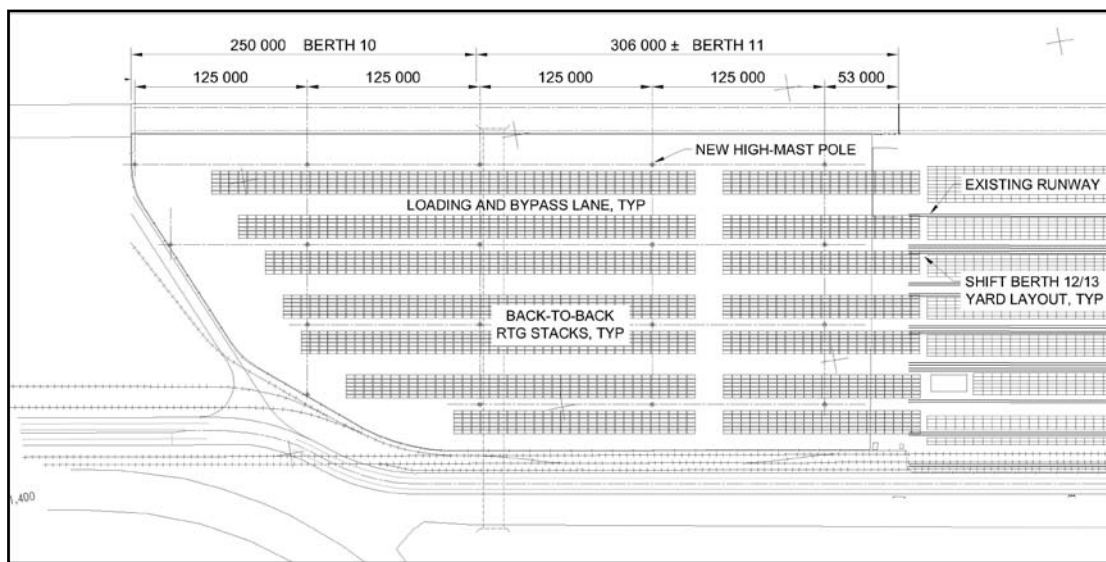

**Figure 3. Berths 10 and 11 container yard layout.**

**Ground Improvement.** The improvement of the existing loose sands and peats in the backland areas had been demonstrated to be a critical part of providing the post-earthquake operation that the owner required. Ground improvement options such as wick drains, vibro-densification, and deep dynamic compaction were considered, but the project team ultimately selected vibro-replacement (stone columns), primarily because of the availability of an economical source of high-quality aggregate for the stone backfill.

The stone columns (800 millimeter [31 inch] diameter) were installed to a depth of approximately 20 meters (65 feet) on a triangular spacing of 2 meters (6.5 feet). Post-installation testing showed that standard penetration N value was increased from an average of 18 to 25 in the areas between columns, a level of densification designed to eliminate approximately 90 percent of potential earthquake-induced settlement. While the level of improvement was selected to optimize cost versus benefit, it is worth noting that the resulting size and spacing matched those of the stone columns installed at Berth 12, which had performed well in the 2003 earthquake.

**Heavy-Duty Paving.** Based on previous experience in the region, concrete block pavers were selected as the paving system for the expansion area. But in adopting the lessons learned from the performance of the existing paving system and concrete RTG runways at Berths 10 and 11, the project team revised the approach to heavy duty paving completely.

By the time the expansion area became available, the terminal operator had converted almost entirely to an RTG operation, using 16-wheel machines as a standard. After an evaluation of wheel loads and transit cycles, the project team determined that dedicated concrete runways were not required, and that the same paving system could be used throughout the terminal. This eliminated discontinuities in paving type and stiffness, which had been a problem in the existing terminal. In addition, the paver layout did not incorporate grade beams to modularize the pavers as had been done previously – pavers are bounded by the wharf approach slab and retention curb at the perimeter, with separation provided only at longitudinal trench drains.

To improve the performance of the pavers themselves, a 50 MPa mix design was selected, with tight controls on cement content and water/cement ratio. But industry experience has shown that increased 28-day design strength does not necessarily ensure a more abrasion-resistant surface. To help ensure that the required durability was attained, the design called for an abrasion testing in accordance with the latest standards. This test setup was not available locally, but a local testing agency was able to develop similar equipment that showed adequate abrasion resistance by the pavers.

The philosophy adopted for designing the paving base was to simplify the design as much as possible. Systems employing concrete- or asphalt-treated base, geogrids, and asphalt concrete had been considered, but once more it was determined to use the same locally available crushed rock that had been used in the stone columns. The project team selected a 900-millimeter (2.9-foot) base of crushed rock, primarily because a similar paving section had been constructed in a top-pick area of the Berth 12 yard two years earlier. While heavy loads and a localized area of poor subgrade had caused the failure of the existing pavers and base in that area, the two years' hard use demonstrated that, even over a poor subgrade, the selected base was adequate.

**Layout Optimization.** The final lesson learned from the operation at Berths 10 and 11 was that the new stacking layout should not only maximize the number of grounded TEU slots per hectare of yard, but also improve truck circulation through the terminal by setting a more logical traffic pattern. The team believed that, by eliminating some of the bypass lanes in the old layout, additional space could be recovered; the challenge was to provide equal or better traffic flow.

The solution came in changing from an RTG layout that had the loading lane on the same side in each stack to a back-to-back layout. That modification, in conjunction with the conversion of the relatively wide bypass areas adjacent to the crane backreach and intermodal areas, freed sufficient space for an additional RTG stack. Figure 4 compares sections through the existing Berths 12/13 yard with those of the

new Berths 10/11 expansion area and shows the shift in stacks and relocation of aisles and lighting.

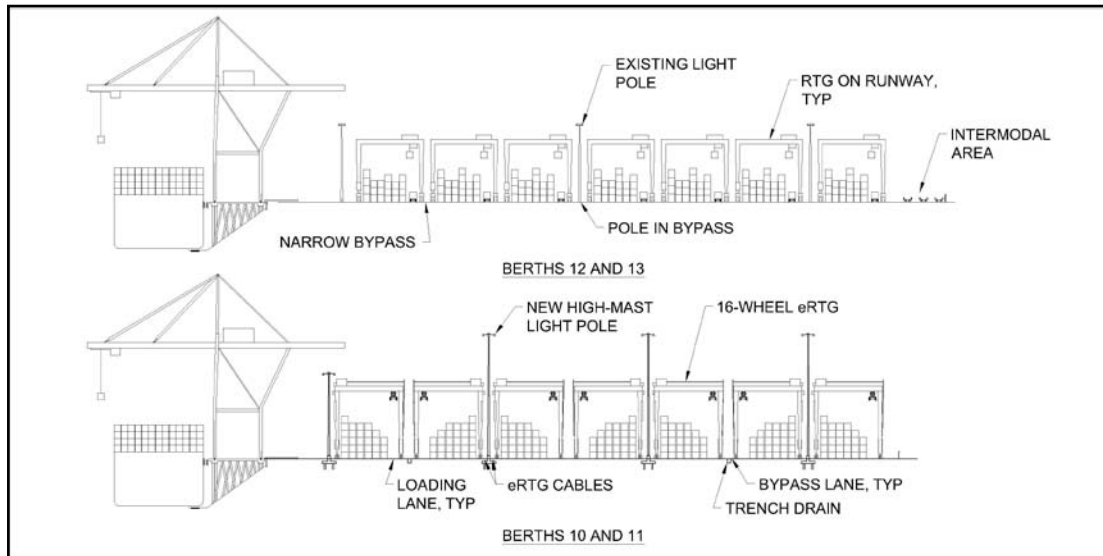

**Figure 4. Comparison of berths container yard sections.**

As shown on Figure 4, the revised layout maximizes the use of the available yard space by allocating a single bypass lane to each pair of loading lanes. Although it was argued that additional space could be made available by eliminating bypass lanes altogether, the long, narrow configuration of the Manzanillo terminal meant that bypass lanes are required to move traffic efficiently from the entrance gate at the north to the exit gate at the south. Using fewer wider bypass lanes has improved the operation significantly, particularly in the case of off-terminal trucks, which had been a major source of congestion in the terminal previously.

The existing container cranes at Manzanillo have a fairly narrow gauge, making it possible to bring the stacking area closer to the wharf area. To further maximize the use of available space, the team determined that providing space for two lanes of traffic between the hatch cover area and the first light pole was sufficient. (The first light pole had to be lowered to fit in the crane backreach.)

Finally, the revised layout simplifies construction of container yard utilities. The high mast lighting and cables for electrified rubber-tired gantry cranes (eRTGs) (see below) are placed in a common duct bank corridor in the back-to-back zone, while storm drainage is provided in the bypass area via a continuous longitudinal trench drain.

**Construction Phasing.** Until the existing yard at Berths 12 and 13 yard is redeveloped to match the new area, not only will RTG stacks not line up, but shifting machines from the old to the new yard often will require the RTG to change its orientation, moving the loading lane from the east to the west, or vice versa. This, in combination with the fact that the movement of trucks is also affected by the reversing load lanes, means that the operator wants to proceed with the

redevelopment of the existing yard as soon as possible. Converting the existing Berths 12 and 13 yard to the new layout will be challenging.

At this time, the new yard has been completed and is in use. Having the added space available for stacking allows the operator take limited sections of the existing yard out of service long enough to complete the changeover. The principal effort at this time is to relocate high mast light poles to bring them in line with those of the new yard and to provide electrical infrastructure in the back-to-back zones for future RTG electrification. It had been determined to leave the existing system of pavers, grade beams, and concrete runways in place for the time being. The condition of the pavement will be monitored and it may be replaced with the new crushed rock and paver system as needed.

### RTG ELECTRIFICATION

The back-to-back RTG arrangement was implemented not only to maximize yard space and improve traffic circulation, but also to accommodate the electrification of the RTG fleet. It was determined early on that a back-to-back configuration would be advantageous because electrical feeders can be common not only to two RTG lines but to the high mast lighting.

Electrification will be accomplished by fitting each machine with a cable reel that will lay cable on the existing pavement. To keep the electrification as simple and cost-effective as possible, instead of using cable trays or other cable guidance systems, the plan includes an above-ground plug connection box located in the shadow of the high mast light pole and a combination tension control bollard and deviator funnel to bring the cable safely from the plug to the guide on the RTG. Figure 5 shows a schematic of this arrangement.

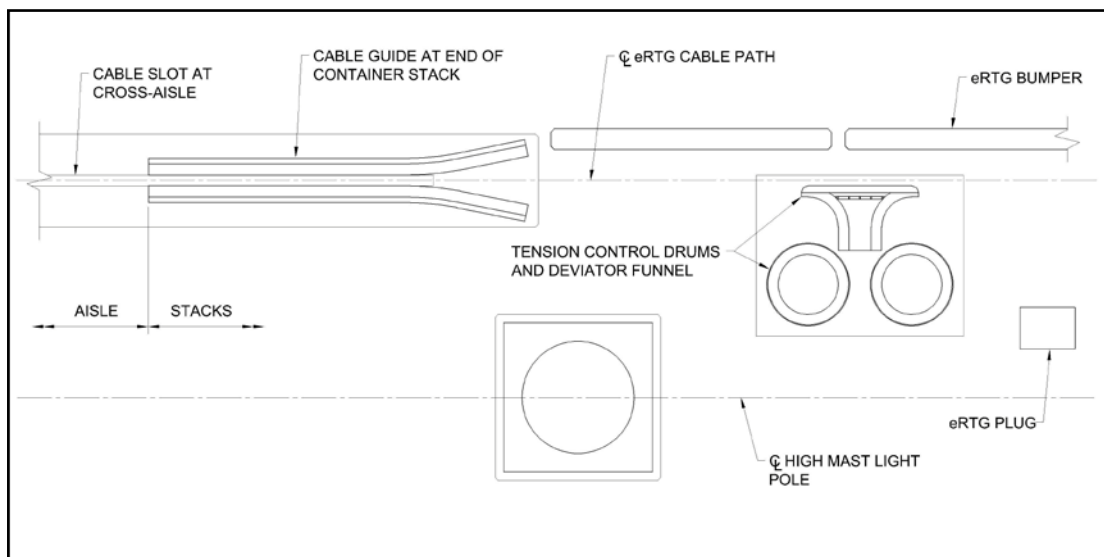

**Figure 5. eRTG plug and cabling layout.**

As shown on Figure 5, the deviator funnel assures that the cable is laid in the correct alignment and that allowable bend radii and tensions are not exceeded. Traveling

away from the funnel, the eRTG lays cable on the concrete paver blocks until it reaches a cross aisle. At that point, barriers for the machine and additional cable deviators bring the cables into line and into a cable slot, allowing the eRTG to cross the aisle without unplugging and re-plugging.

### **ADDITIONAL SHIP-TO-SHORE CRANES**

To match the increase in throughput capacity the expanded container yard provides, the owner elected to provide two additional ship-to-shore container cranes at Berths 10 and 11. As with cranes previously brought to the terminal from Panama, the two new cranes for Berths 10 and 11 were relocated from other facilities – in this case, from Long Beach. Because of the relatively uncommon 16.76-meter (55-foot) crane gauge at Manzanillo, previous crane relocations had incorporated structural modification to change the cranes' gauge.

However, the Long Beach cranes for Berths 10 and 11 had an existing gauge of 30.48 meters (100 feet), and reducing their gauge to 16.76 meters (55 feet) was not feasible. The design team proposed the construction of a new third crane rail behind the existing wharf and the maintenance of the current gauge of the new cranes. While this solution appeared operationally and economically feasible, could space be made in the newly reconfigured yard for a third rail 13.72 meters (45 feet) behind the existing landside rail? The team also had to assess the implications for RTG operation, traffic flow, and high mast lighting.

Fortunately, the increase of 13.72 meters (45 feet) was approximately equal to the space allocated for hatch cover laydown. Therefore, simply placing hatch covers between the legs of the crane rather than in the backreach preserved the bypass lanes nearest the first light pole row. As Figure 6 shows, the resulting arrangement also kept the continuity of the loading lanes on the wharf, which of course had been configured for the 16.76-meter (55-foot) gauge of existing cranes 1 through 6.

The new rail is supported on a cast-in-place concrete crane beam bearing on steel piles installed at 3 meters (9.8 feet) on-center. The design incorporates structural ties consisting of reinforced concrete grade beams connecting the third rail beam to the existing wharf at regular intervals. These tie beams maintain a constant rail gauge and also serve as drag struts to transmit inertial loads to the existing wharf in the event of an earthquake. The third rail project also incorporated new crane pin sockets and tie-downs, which were aligned with the existing waterside hardware so as to eliminate the need for additional retrofit or reconstruction.

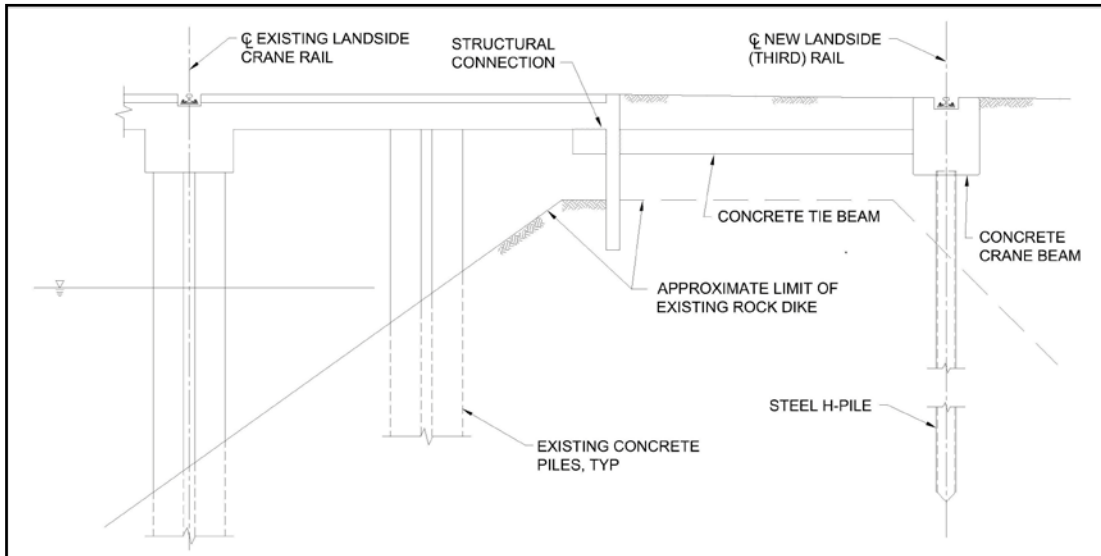
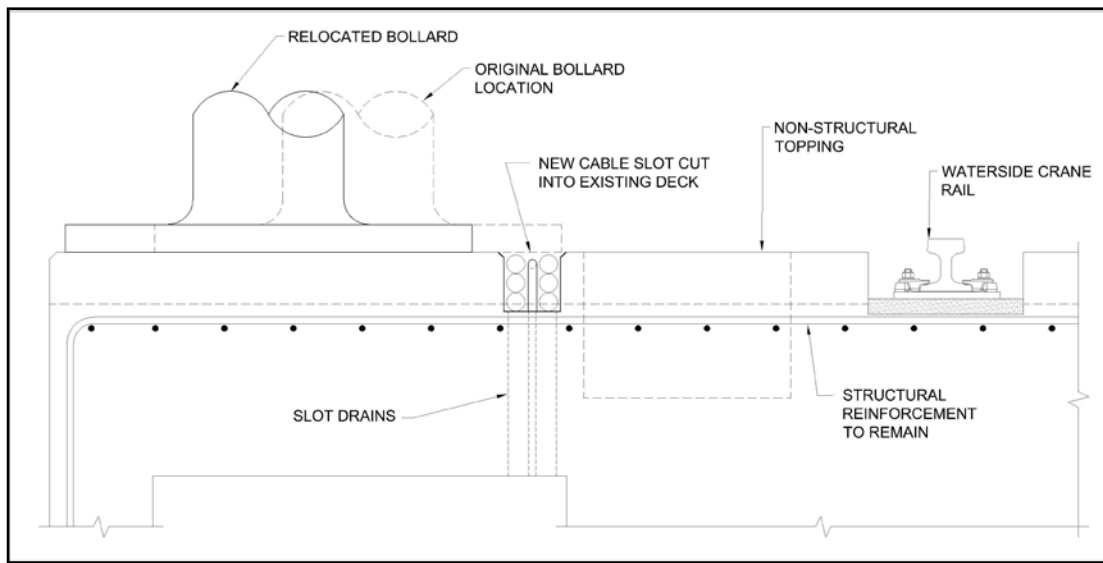

**Figure 6. General arrangement of third rail and new/existing cranes.**

### **CABLE SLOT RELOCATION**

Relocating the existing crane power cable slot from just behind the landside crane rail to a position outside the waterside crane rail was also addressed during the redevelopment of the terminal. The slot's original position, which dated from construction of Berth 13 in 1991, was an ongoing maintenance concern – trucks often hit the slot as they transited to and from the wharf. Although the slot was provided with a flexible cover system, it had deteriorated so much that damage to the cable itself also was a concern. The team decided that relocating the slot to the wharf face – while difficult and possibly disruptive – was the best solution.

To create sufficient space for the cable slot, the existing bollards had to be shifted closer to the face of the wharf. Once that had been accomplished, a double slot was cut into the existing non-structural topping to provide sufficient width and depth for a total of six cables at any one location. The only exception was at the existing Berth 12, where the demolition required to create the slot conflicted with structural reinforcement. In this case, the existing deck was reinforced from below prior to cutting the new slot. Figure 7 shows the configuration of the wharf, including the bollards and crane rail pocket, both before and after the installation of the new cable slot. The work had to be phased and coordinated carefully with operations staff to limit down time.



**Figure 7. Waterside crane cable relocation detail.**

## **CONCLUSIONS**

By working closely with operations staff, project designers and construction managers were able to plan and implement terminal improvements that increased the throughput potential of the Manzanillo container terminal significantly. The owner took a long-term view of the improvements, the terminal operations staff and the design and construction management team were able to demonstrate the benefits of the redevelopment work, and this team approach made the potential benefits a reality.

## **ACKNOWLEDGEMENTS**

The authors wish to express their gratitude to BergerABAM and SSA Marine for their generous support of the preparation of this paper. In particular, the authors would like to thank SSA Mexico Regional Vice President, Gene Smith, and SSA International Director of Engineering, Ricardo Cheng.

## **REFERENCES**

Comision Federal de Electricidad. (2001). Manual de Diseno de Obras Civiles, Diseno por Sismo. México, D.F. 2001.